

English

# **RAKET 85**

**Radne Motor AB**

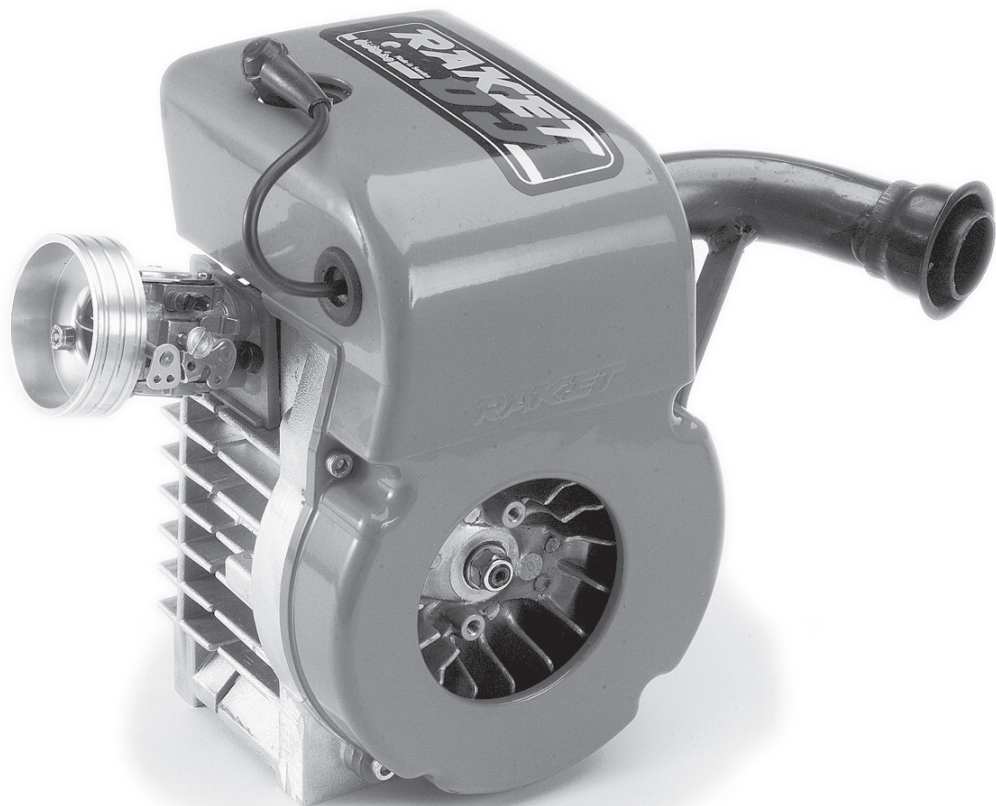

## **Users Manual**

## **Introduction**

We at Radne Motor congratulate you to your choice of the Raket 85 go-kart engine.

With this manual we will try to give you hints regarding the running and the maintenance of your new engine. It is our sincere hope that your new engine will give you lots of fun and very few problems.

If you follow our simple instructions in this manual you can avoid many costly mistakes.

We recommend you to read the complete manual, even if you are an experienced go-kart mechanic.

You can still pick up a few things on how to maintain and service the engine.

You can always find an updated version on this manual or other things that could be of interest at our Raket website: <http://www.radne.se/raket/>

### **Radne Motor AB**

Radne Motor AB was founded in 1967 by Leif Radne to produce and sell engines and parts for go-kart. Today almost 40 years later it is still main business concept of the company

We have now expanded our range of products to include paraglider engines.

Radne Motor is one of the major go-kart engine producers in the world, and exports the range of engines to more than 60 countries.

### **Radne Motor AB**

Box 3035  
S-136 03 Haninge  
Sweden

Tel: +46-8-556 506 90  
Fax: +46-8-556 506 91  
e-mail: [info@radne.se](mailto:info@radne.se)  
home page: [www.radne.se](http://www.radne.se)

Rev 1, 2005-01-14

© Radne Motor AB 1998-2005

## Raket engines

The first Raket engine was introduced in 1972. Extensive re-search for a reliable, simple to use, yet fun to drive go-kart engine at an acceptable price, had convinced Radne Motor to start the manufacture of such an engine. Power chain saw engines are the toughest two stroke engines that are built, and Radne Motor decided to build the go-kart engine on well-tested vital parts. Hence, cylinder and piston, crankshaft, carburettor and ignition system were purchased. Radne Motor manufactured other parts that are typical for a go-kart engine, like the aluminium crankcase. Finally, the engine was assembled and tested by Radne Motor before it was shipped. All Raket engines have been built around this concept, which has proven to be very successful.

**Today the Raket line of engines consist of:**

**Raket 60** for the very young drivers. This engine has rope start, centrifugal clutch and forced air cooling. It can be equipped with catalytic emission control and a rev. limiter.

**Raket 85** is the most popular and most produced Raket engine. It is used in many countries for the youngest drivers. Often the same engine is used with some type of power restrictor for the youngest, and later, with the restrictor removed, for the more professional drivers. The Raket 85 engine has a whole series of extras and conversion kits, so it can be used also for indoor driving and for rental kart use.

**Raket 120** is used mainly for Ultra Light Aircraft, so called Paragliders. This engine is extremely powerful for its low weight. But Raket 120 has found many more uses, both for go-kart and where the low weight in combination with high power and good reliability is appreciated.

Spare parts and service for the Raket engines are available from Radne Motor or from our distributors. We recommend that you consult our catalogue. A new catalogue is produced every year, in which you find the latest parts and also hints for the best use of your Raket engine.

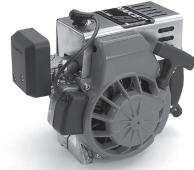

**Raket 60**



**Raket 85 Racing**



**Raket 120**



**Raket 120 Aero ES**

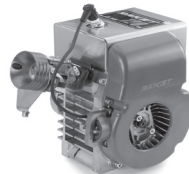

**Raket 120 Racing ES**

## **To the new owner of a Raket 85 kart engine**

Please read the following two pages. It will take you perhaps 15 minutes, but it can save you a lot of aggravation and money in the future.

We congratulate you to your new Raket 85 engine. We hope you will have a lot of fun with it.

This engine is especially developed for the two junior classes Micro and Mini, for drivers 10-12 and 12-15 years of age.

When you read the following pages you will find numbers that refer to the exploded view on page 19. Numbers in the text with six digits are spare part number engraved into the part in question. All four digit numbers are our own part numbers. See the spare parts list on page 18.

## Mounting the engine on the kart

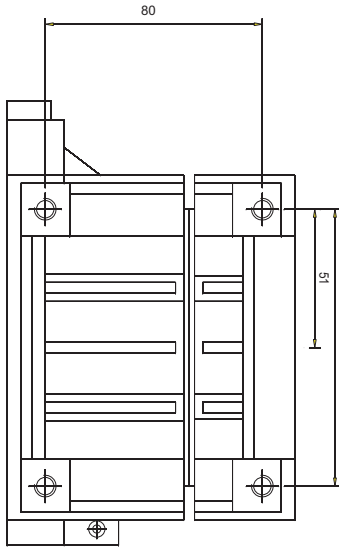

For this purpose use original engine mount for the kart. We have a special engine mount for the Raket 85 engine, which makes the mounting to the frame very simple. The part number for the engine mount is 3004. Please see illustration for drilling instructions.

When you have mounted the engine to the frame, you must link the carburettor with the accelerator. We have made a special throttle linkage (no 3083), which makes it easy to do this. We recommend that you have an extra return spring that helps to close the throttle, in order to make sure that the throttle closes every time you release the accelerator.

Finally, you connect the fuel hose to the carburettor. Use a transparent, flexible hose with an inner diameter of 6 mm. Flexible hose and muffler

**Note!**

Check that the flexible exhaust hose tightly surrounds the beginning of the conical part of the muffler. This is very important!

The Raket 85 kart engine is homologated with the muffler 3012 in the Mini class, and with the muffler 3140 in the Micro class.

Between the muffler 3012 and the exhaust pipe 3132, you must use a flexible hose (our number 3010). The length of this flexible metal hose is important. One part of adjusting and tuning your kart to a new track is to try out a suitable length of this flexible hose.

The principle is that the longer you make the hose, the stronger the engine will be at low revs. And, the shorter you make the hose, the higher the engine will rev up. You should start with a standard length of 660 mm, see illustration, and then try out the most suitable length.

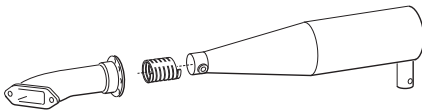

**This is how you measure the length:**

Measure from the gasket (3053) between the cylinder and the exhaust pipe, along the exhaust pipe, the flexible hose and the muffler (that is the length along the outside).

If you want to change the total length, simply change the length of the flexible hose.

## **Carburettor setting**

If you mounted the engine on the kart according to the description, you are now ready for your first test run. Select a "normal" gearing. We suggest 11 teeth on the engine sprocket (this is standard) and 80 teeth on the rear axle sprocket, this we call 11:80 gearing. Grease the chain with special chain grease, and don't forget to mount the protection over chain and sprockets.

Always use inlet silencer to lower the noise and protect the engine from dirt.

### **Now let us make the basic setting of the carburettor:**

Turn both the fuel needles (marked L for Low rev mixture and H for High rev mixture) gently clockwise until you feel that they bottom.

Now open (anti clockwise) the H needle 1 turn and the L needle 1 turn.

This is the basic setting, and we guarantee that you can run the engine with this setting as long as you practice to get used to the engine and the kart. You can lower your lap times with some tenths of a second if you screw the H needle clockwise (this gives leaner fuel mixture) – **BUT YOU MUST NEVER CLOSE IT MORE THAN TO ½ A TURN OPEN.** If you close the H needle, you **MUST** open the L needle to enrich the mixture at low revs, Let us say L needle will be 2.5 full turns open. The correct setting of the two needles is one of the secrets of the successful kart mechanics, but here are some hints:

Look at the sparkplug. It is white, the mixture is too lean. If it is black or wet, the mixture is too rich. Correct setting shows a light brownish color of the sparkplug electrode.

If the H needle is correctly set, you will notice that the engine goes over in 4-stroke just at the end of the longest straight.

If the L needle is correctly set, the engine will respond immediately when you push the accelerator after you have had it released (e.g. after a sharp bend).

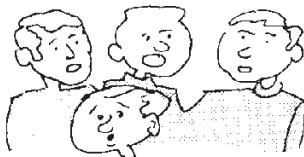
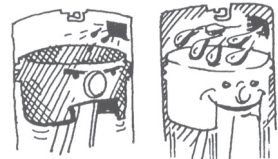
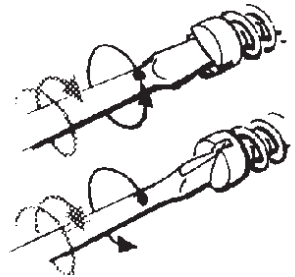

The best advice we can give you, and this can save you a lot of money, is that you take advice from someone who has experience of the Raket engine BEFORE you try some extreme carburettor settings. No engine has taken serious damage of a too rich mixture, but many, many have broken down because of too lean mixture.

### **Fuel**

The Raket engine works well on unleaded fuel, but we recommend 98 octanes, with a 5 per cent mix of 2-stroke oil. We don't recommend the use of so called outboard oil. The engine can also run on 2- stroke oil intended for extremely low mixture, normally 1 per cent. But, if you use such oil, you must be very careful when you mix fuel and oil. This is the reason why we recommend this type of oil only if you get it in small packages ready to be mixed with 5 or 20 liters of fuel. Ready-to-use oil in such small packages is available for the Raket engine from Radne Motor.

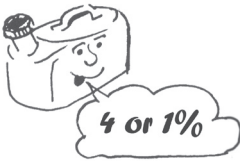

### **Driving under rainy conditions**

When driving under rainy conditions it is absolutely necessary to protect the carburettor from water splashes and water mist. If too much water is allowed to enter the engine, very serious engine damages, e.g. on cylinder and piston, can occur.

## Service advice

If you are not satisfied with the performance of the engine, and other karts are faster down the straight or out of the bends, it does not necessarily mean that your engine is no good. It could mean that it needs basic adjustment of the carburettor or ignition system. Of course, the piston or the piston rings could be worn out, the radial sealing rings could be leaking or a bearing on the crankshaft could be worn out. But more likely, the difference between a good engine and a tired one is found either in the carburettor or in the ignition system.

So here are some hints on how to check and adjust the carburettor and the ignition system.

The carburettor used on the Raket 85 engine is a membrane carburettor with a built-in fuel pump. It is made by Tillotson in Ireland, and has the designation HS. If we follow the gasoline through the carburettor it is easy to explain the function of the carburettor. The carburettor has two covers, one is made of steel and the other is made in aluminum casting. Under the aluminum cover is found a rubber membrane, called the pump membrane, and a gasket, on each side of the membrane is a small chamber. One of these is directly connected to the crankcase with a channel. When the pressure in the crankcase varies, it will move the pump membrane up and down. On the other side of the membrane, in the other chamber, is the fuel. When the membrane moves, it pumps gasoline in and out of the chamber. Two small valves are punched out from the same piece of rubber as the pump membrane, and they now act so that fuel is sucked from the fuel tank and pumped into the main carburettor. The pump shall give a pressure of 0,5 kp/cm<sup>2</sup>. It is very easy to check if the pump is working. Unscrew the sparkplug to make it easier to rotate the engine. Check that the fuel hose is connected correctly and that the carburettor is mounted correctly on the engine. Check all gaskets, especially the gasket between carburettor and the engine so that there is no leaking, or is blocking the channel. Then push down carefully the main membrane with a small screwdriver through the little hole in the punched steel cover of the carburettor. This will open the fuel inlet needle valve.

Now rotate the engine, and check through the transparent fuel hose if fuel is flowing from the tank to the carburettor. If it is not, push down the main membrane, loosen the fuel hose at the tank end, and blow carefully into the free end of the hose. You shall be able to blow slowly through the hose and the carburettor. If you can't, take away the aluminum cover and check the small fuel filter (no 43 on the spare part list) – it could be blocked. After that, check the pump membrane – it can be broken. That can be

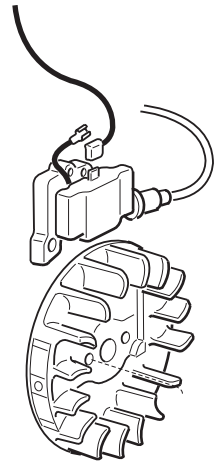
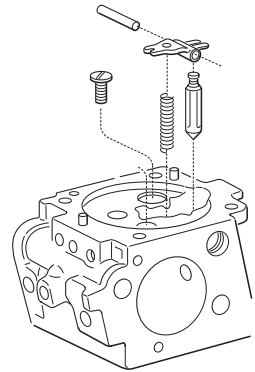

very hard to see, so if it has been used for some time – change it. When you change the pump membrane, always change the gasket too. The membrane shall always be placed nearest to the carburettor housing, otherwise the valves will not work. Then take a last check of the channel between the crankcase and the carburettor.

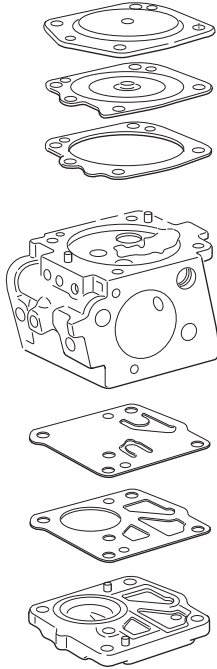

Now check the pumping action again. If it still doesn't work, check the needle valve (see below) in the carburettor, which could be stuck. The pump pushes fuel towards the needle valve, but can't open it. Let us look at the other side of the carburettor. If you take off the steel cover you will find another membrane, a lever with a spring and a needle valve. The needle valve is held in closed position by the spring working through the lever. The lever rests against the main membrane (which can be recognized by the small rivet in the middle of the membrane). The lower side of the main membrane and a cavity of the carburettor housing form a small fuel reservoir. When air is rushing through the carburettor, the fuel under the main membrane is sucked out. The fuel lever under the main membrane is now reduced. The membrane is moving downwards and forces the lever to open the needle valve. Now more fuel comes in from the pump side of the carburettor. The membrane moves upwards and the lever can close the valve. This is how the carburettor keeps a steady level of fuel.

From the chamber under the membrane the fuel goes through the H and L needle valves to the venturi of the carburettor. The channels are so thin that the fuel does not pass through unless it is sucked. The design and location of the small holes through which the fuel can enter into the venturi are of great importance for the characteristic of the carburettor.

Now for some service hints. Let start with the needle valve. First take off the steel cover and the main membrane with its gasket. Then loosen the little screw under the membrane. Now it is possible to dismount the needle valve. Don't loose the spring.

Check the needle valve. The conical rubber end must be smooth. If you can see impressions – change the valve. Check the bottom of the hole that the needle valve is sitting in. It shall also be smooth. When you have cleaned everything, start to assemble the needle valve with its lever and spring. The spring and the lever must not be deformed (you shall have some as spare parts). When you have assembled the needle valve, the arm of the lever that is in contact with the membrane shall be at the same level as the adjacent level of the carburettor.

**How to check the correct opening pressure for the needle valve.**

Connect a small air pump with a manometer to the fuel nipple of the carburettor. Drop some fuel on the needle valve and pump up some pressure. At 1.0 kp/cm<sup>2</sup> the needle valve shall open – and you can see that it bubbles around the needle valve. Now reduce the pressure down to 0,5 kp/cm<sup>2</sup>. Check with a few more drops of fuel that the valve is tight – no more bubbles. If the valve is leaking all the time, clean everything again and change to a new valve and spring.

If the opening and closing pressure don't match the values given in the text, you have to change the spring and lever until it is correct. Finally, take a last check of the main membrane and the gasket, there is very little that can go wrong with these. If the carburettor is carefully cleaned and you have checked everything according to the instructions and the H and L needles are OK – the carburettor works.

The only problem that can remain now is if the engine is very difficult to start and don't react on adjustments of the L-needle. Then there could be dirt under the expansion washer, which is located under the main membrane. The fuel that passes the L-needle is also passing a small chamber on its way to the venturi. In very rare cases this chamber can be blocked. To solve this problem you have to drill a 2 mm hole in the middle of the washer (3020) and pry a thin tool into the hole and bend up the washer. Clean and check all channels to and from the chamber carefully and seal it with a new washer. To do this, place a new washer in correct position and expand it with a gentle blow of a small hammer. That is all, now your carburettor shall be working. Normally this membrane carburettor will give you very few problems, but sometime you get a carburettor that doesn't give good results. Then try to borrow a carburettor that you know works well. If the difference between the two is big, you have to buy a new carburettor. It is very difficult to change a band on into a good one.

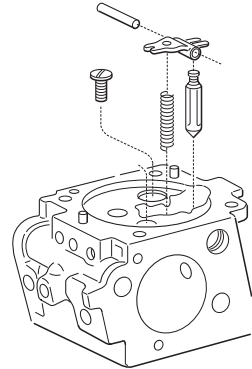

## The ignition system

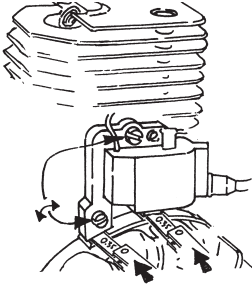

The Raket 85 is equipped with a transistor ignition system, which is specially made for Raket kart engines. It is very reliable. Normally it does not give any problems.

Adjustment of the Raket 85 ignition system starts by adjusting the distance between the flywheel and ignition unit. This is done with a non magnetic thickness gauge of 0.35 mm. It is important that you make the measurement when the poles of the flywheel are right opposite to the poles of the ignition unit. Then put the 0.35 mm gauge between the poles and tighten the screws that hold the ignition unit.

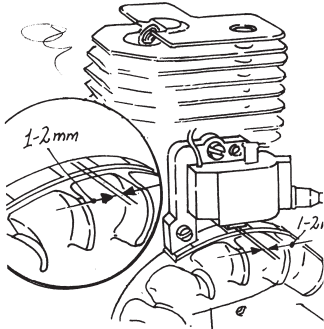

Now check the ignition timing. Put a dial gauge clock into the sparkplug hole. Turn the flywheel until the piston is in the top position, (top dead centre) and note the value. Then turn the flywheel backwards and observe the dial. Stop when the dial shows 2.5-2.7 mm before top dead centre. At this point the ignition system shall generate a spark. Look at picture to see the correct position of the flywheel in relation to the ignition unit.

Between 2.5-2.7 mm before t.d.c. The engine gives its best performance. But if the ignition points isn't correct, what to do? You have to dismount the flywheel and adjust the flywheel key. You machine the key so you can move the position of the flywheel to get the correct ignition point. You probably have to try many times to get it right. Note that the key is not necessary for keeping the flywheel on the crankshaft, it just makes it easier to find the correct position for the flywheel. This is all you can do to adjust the ignition system.

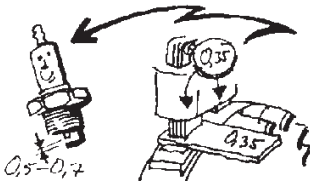

## Maintenance of the ignition system

Very few things can happen to the ignition system. But, regularly check the sparkplug cable at both ends, the vibrations can break the cable. Change sparkplug frequently, and put some grease on the connection to the coil.

GOOD LUCK WITH YOUR RAKET 85 KART ENGINE!

# Product Description

**Note!**

Most part of the product description only covers the rules in the scandinavian countries.

This product description is only a supplement to the homologation form for the Raket 85 engine. In case of doubt, you must first consult the homologation form, and then, if you don't find what you are looking for, you read this product description.

For conversion of millimeters to inches – 1 mm corresponds to 0,03937 inches.

## 1. The crankcase

The crankcase must have the same shape as is shown in the homologation form. The measures that are especially important are those for the parts of the crankcase which surround the crankshaft. These measures must not be changed.

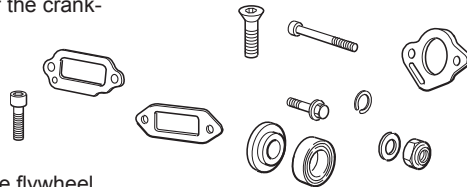

The part of the crankcase which surrounds the flywheel must also remain unchanged (no machining allowed).

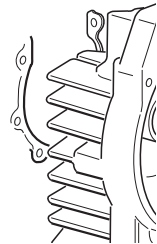

The part of the crankcase which is closest to the drive sprocket must also remain unchanged, with the exception that is acceptable to make necessary modifications at the outside in order to be able to fit a suitable guard over the sprocket and chain.

The sealing rings are “free”, i.e. you can change the make as long as the type and the size remain the same. On the sprocket side there must be a 17x28x7 mm single sealing lip type, and on the flywheel side, a 15x26x7 mm with both a sealing lip and a dust cover lip.

The ball bearings (they normally stick on the crankshaft when you disassemble the crankcase) are in original SKF 6203 C3 bearings. They are “free” in respect to the make, but must be of deep groove ball bearings type and be mounted at the same place as the original.

## 2. The crankshaft and connecting rod

No machining of any kind or any other modification of the crankshaft is allowed. You must not change the balancing of the crankshaft through machining or addition of material.

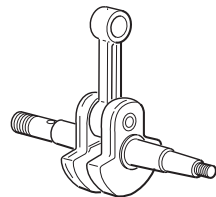



You must not machine or modify the connecting rod in any way.

The needle bearings at both ends of the connecting rod are “free” in respect to the make, but must be of the same type as the original bearings (a needle bearing in a steel cage).

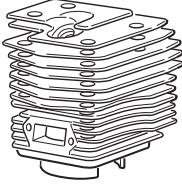

### **3. The cylinder and the sparkplug**

The cylinder must remain totally unmodified, i.e. no machining of any kind is allowed. For instance, deburring the edges of the cylinder ports is regarded as machining and is therefore not allowed. The sparkplug is “free”. If the thread in the cylinder for the sparkplug should be damaged, it is accepted to repair it with a thread set of HeliCoil type or similar.



### **4. The piston**

It is only the original piston that you are allowed to use, without any kind of machining or modification. The piston is always marked with the name of the manufacturer (Radne), but other markings on the crown of the piston may vary.

The markings on the piston crown are, except for the name of the manufacturer, an A with an arrow showing which side that must face the exhaust port. Further, on the original pistons you may find a classification letter, where A indicates the smallest diameter and B, C etc. indicate larger diameters.

The pistons which are sold as spare parts may not have any classification letter at all, but all spare parts pistons are class AB and can be mounted in all cylinders.

The piston rings, the gudgeon pin and the clips are “free”, i.e. may be changed to similar parts of another make, as long as the measures remain the same as for the original parts.

### **5. Standard parts**

Gaskets, nuts, bolts, screws and washers are standard parts and as such they are “free”.

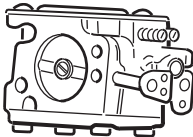

### **6. The carburettor**

The carburettor must be original Tillotson, serie HS. No modifications are allowed.

The venturi (the most narrow part of the channel through the carburettor) must have a diameter of maximum 17,7 mm. The diameter of the channel closest to the carburettor manifold must be 20,5 mm.

For the class 12-15 years of age (in the Nordic countries called class Mini), you may remove the choke shaft.

The following external modifications of the carburettor are allowed:

- you may make the modifications needed for fitting the throttle linkage, but only under the circumstance that it has no effect on the function of the carburettor
- you may change the gasoline inlet nipple

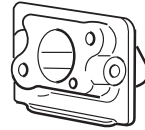
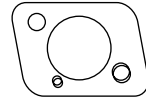

### **7. Restricted washer**

In the Micro class there should be a restricted washer between the carburettor and the manifold, one washer with 12 mm hole and a distance washer 20 mm hole.

### **8. The carburettor manifold**

This part must bear the spare part number 279 189 and may under no circumstances be machined. Deburring is regarded as machining.

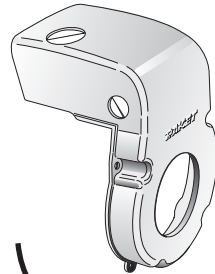

### **9. The fan cover**

The fan cover is standard for Raket 85. It must not be machined. The circular air inlet opening must have a diameter of 80 mm (+-1).

### **10. The ignition system**

The ignition system is of a transistorized type, and is especially developed for Raket 85. It must not be changed against any other type or make of system. It is further forbidden to move the ignition system from its original position.

The flywheel must be original Raket 85, but there may be several different original types. See homologation sheet for more information och local rules.

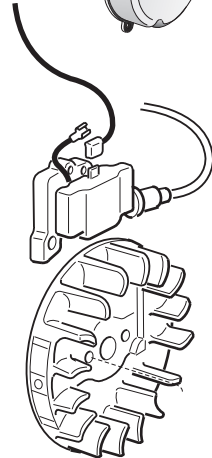

Note!

Apart from the fact that it is forbidden to machine the flywheel, it is also very dangerous. If you machine the outer perimeter of the flywheel, it might explode when you run the engine at high revs.

The key for the flywheel is "free". You may machine it or even remove it completely.

### **11. Air filter**

Use CIK homologated inlet silencer.



### **12. Exhaust pipe with flexible hose**

For the class 10-12 years of age, the Raket 85 engine must be equipped with original exhaust muffler and spacer (part numbers 3140 and 3127).

For the class 12-15 years of age, the exhaust pipe is completely "free", including the diameter of the pipe. But the pipe must always

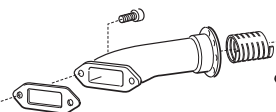

be mounted to the cylinder with two bolts in the two original holes on the exhaust side of the cylinder.

The flange of the pipe must not have a hole with larger dimensions than the exhaust channel of the cylinder, measured closest to the flange.

The flexible hose is "free" regarding length and diameter.

### **13. The exhaust muffler**

It is accepted to connect the muffler directly to the exhaust pipe, without using a flexible hose.

For class 10-12 years of age, the original muffler 3140 and the spacer 3127 are compulsory.

For the class 12-15 years of age, the original muffler 3012 must be used.

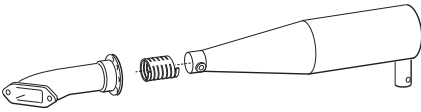

### **14. The chain sprocket**

The number of teeth on the sprocket is "free".

The sprocket must be fastened to the shaft with a separate nut.

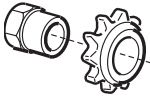

### **15. The distance between the piston and the cylinder top**

The minimum distance is 1,3 mm.

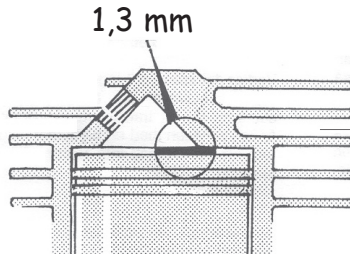





- 3013 Plate
- 3014 Screw
- 3015 Choke axle
- 3016 Cap
- 3017 Main diaphragm
- 3018 Gasket
- 3019 Screw
- 3020 Expansion cap
- 3022 Screw
- 3023 Axle
- 3024 Lever
- 3025 Valve
- 3026 Spring
- 3027 Expansion cap
- 3028 Sirclip
- 3029 Fuel elbow
- 3030 Tube fitting
- 3031 High speed mixture screw
- 3032 Spring
- 3033 Ball
- 3034 Spring
- 3035 Low speed mixture screw
- 3036 Spring
- 3037 Screw
- 3038 Trottleshaft
- 3039 Bushing
- 3040 Spring
- 3041 Control plate
- 3042 Filter small
- 3043 Filter
- 3044 Screw
- 3045 Diaphragm
- 3046 Gasket
- 3047 Pump cover

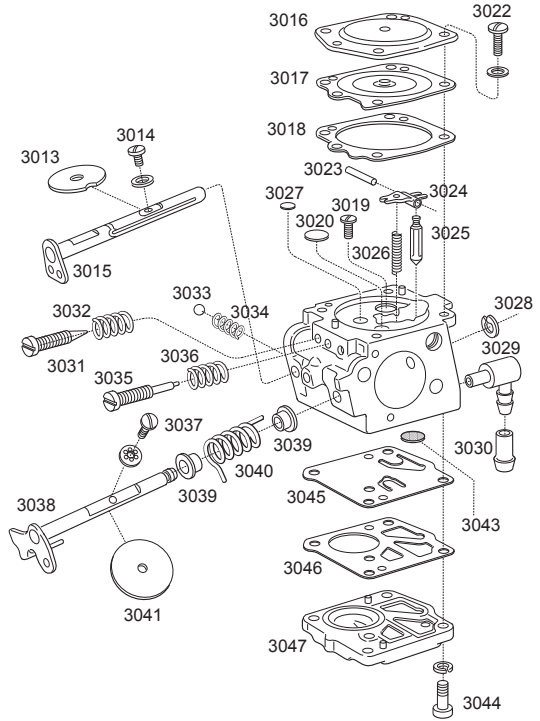

3007	Spring 40 mm	3140	Silencer box model
3010	Flex	3140-1	Silencer box, catalytic converter
3012	Silencer	3150	Crankcase
3012-1	Silencer with catalytic converter	3151	Crankcase gasket
3048	Carburettor HS-175	3158	Rubber bushing
3048-1	Carburettor HS-205	3161	Carburettor flange aluminium
3053	Exhaust gasket	4060	Pin screw
3054	Cylinder screw 5x25	55109	Screw allen key 4x20
3055	Sparkplug	55124	Screw allen key 5x12
3056	Sparkplug cap	55126	Screw allen key 5x20
3059	Aircover	55129	Screw allen key 5x25
3063	Carburettor gasket	55140	Screw allen key 5x45
3065	Inlet flange	55143	Screw allen key 5x55
3066	Inlet gasket	55146	Screw allen key 5x90
3076	Ignition system	55330	Nut M8x1
3077	Ignition cable	55407	Washer M4
3085	Cylinder complete 85 cc	55409	Washer M5
3086	Piston ring	55412	Washer M8
3087	Piston complete 85 cc		
3089	Circlip		
3090	Cylindergasket		
3091	Needle bearing		
3092	Crankshaft		
3093	Bearing SKF 6203		
3095	Key		
3096	Sprocket nut		
3097	Engine sprocket 11 K		
3098	Engine sprocket 10 K		
3099	Oilsealing sprocket side		
3115	Oilsealing ignition side		
3115-1	Oilsealing ignition side teflon		
3116	Flywheel		
3127	Exhaust flange		
3132	Exhaust bend		

**RAKET**  
original

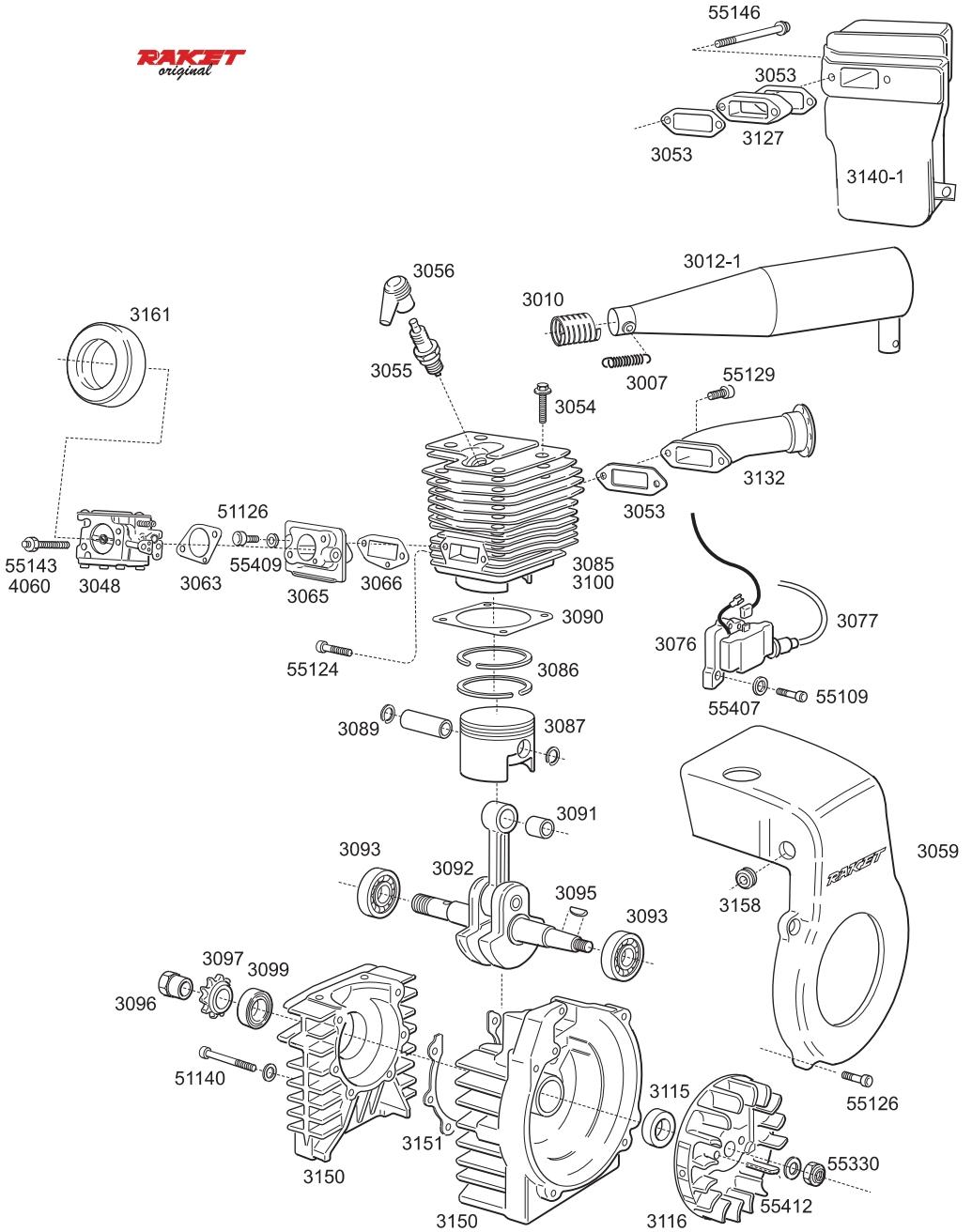

**Radne Motor AB**, Box 3035, 136 03 Haninge, Sweden

Tel: +46-8-556 506 90, Fax: +46-8-556 506 91

[info@radne.se](mailto:info@radne.se)

<http://www.radne.se>